



Load Holding Valves

Normale T11A 3:1 adjustable setting



MANIFATTURA ITALIANA DI VALVOLE OLEODINAMICHE

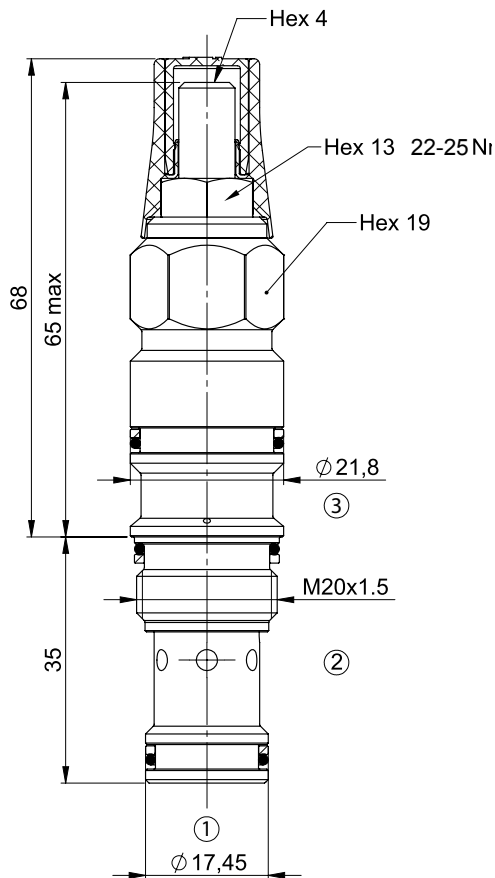
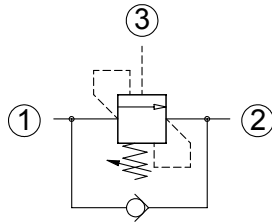

Technical Details

cavity	T11A
capacity	60 lpm (16 gpm)
max operating pressure	350 bar (5000 psi)
pilot ratio	3:1
maximum setting	420 bar (6000 psi)
minimum setting	30 bar (450 psi)
pressure increase per turn	201 bar (Spring D) - 135 bar (Spring M) - 33 bar (Spring T) - 235 bar (Spring S)
pressure setting established @	cracking pressure (1in3/min)
maximum valve leakage at reseal	5 drops / minute
operating characteristic	standard
reseal	>85%
maximum recommended load pressure at maximum setting	320 bar (4600 psi)
valve hex size (mm)	19
valve installation torque	40-45 Nm (30-35 lbf ft)
adjustment screw internal hex size (mm)	4
seal-lock hex size (mm)	13
seal-lock torque	22-25 Nm (16-18 lbf ft)
valve weight	0.150 Kg (0.33 lbs)
external component surface treatment	zinc plating
seal kit (nbr)	S00T11ASN900000
seal kit (viton)	S00T11ASV900000
temperature range	-30 to 100°C (-22 to 212°F) with BunaN seals;
fluids	Mineral-based or synthetics with lubricating properties at viscosities of 10 to 500 mm ² /s (cSt)
filtration	Nominal value max. 10µm (NAS 8) / ISO 4406 19/17/20

- Turn adjustment clockwise to increase setting
- Backpressure at port 2 adds to the effective relief setting at a ratio of 1 plus the pilot ratio times the backpressure.
- Set your counterbalance valve at least 1.3 times the maximum load induced pressure.
- This valve is not provided with positive seals on the pilot section
- Declared reseal value is obtained with valve set @ maximum setting

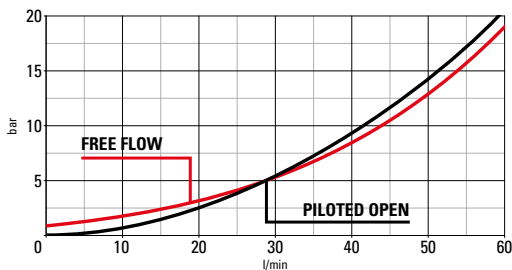

Performance curves

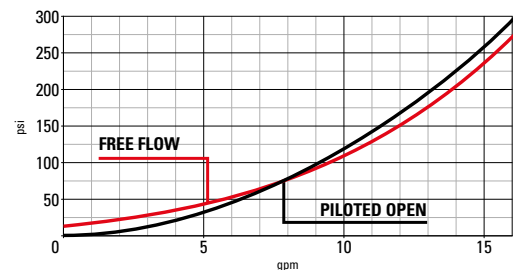

Seals and anti-tamper options

- 0 = BUNA SEALS
- 6 = BUNA tamper resistant
- 2 = VITON SEALS
- 7 = VITON tamper resistant

C | 0 | 0

Setting (bar)

0 | 3 | 1 | 1 | 0 | 0 | A

Spring

- T = 30-105 bar
- M = 105-210 bar
- D = 200-350 bar
- S = 340-420 bar

The information contained in this page is valid at the time of going to print. Valvole Italia reserves the right to modify its products without notice and does not accept liabilities for damages incurred as a consequence of these changes. To make sure you are seeing the latest product information, please visit www.valvoleitalia.it

